



Vacuum for Baking

A Game Changing
Technology
for Bakeries

webervacuum.group



Sales | Rentals | Support | Refurbishments

We are vacuum cooling

Weber Cooling is the largest supplier of vacuum cooling solutions in the world. We have mastered the unique technology of vacuum cooling and can therefore confidently say that we are specialists in this field. Thanks to our expertise and economies of scale, we have developed equipment with unsurpassed value for money.

Vacuum cooler solutions for

- Bread & Bakery
- Convenience Food & Industrial Kitchens
- Rice & Sushi
- Vegetables & Herbs
- Flowers & Cold Chain
- Turf & Compost



Watch our videos



What will be improved and optimised?



Quality

Shape & Volume
Crust & Structure



Productivity

-95% cooling time and space
+50% production



Shelf life

Crispiness - Freshness
Use-by date

Vacuum cooling innovating the art of baking

Vacuum cooling offers new possibilities for the preparation of bread and bakery products. After all, our vacuum cooling solution is not just a cooling system. It will become part of your baking process because 20 to 40 percent of the total baking time is transferred from the oven to the vacuum cooler. The starch gelation process continues due to the presence of steam during the cooling process, allowing your products to further bake while cooling at the same time.

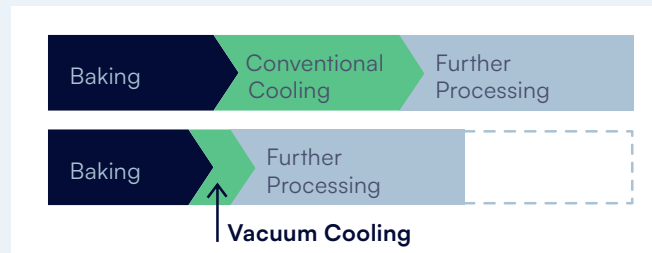

The necessary steam is created by reducing the pressure in the chamber: The lower the pressure, the lower the cooking point of water! The vacuum forces the water in the bread to continue to cook: On the one hand this allows the baking process to continue, on the other hand the energy needed for the cooking is taken from the bread. As a result, the bread is baked cold.

Vacuum cooling has many advantages for bakers. The quality of both the crust and the crumb is optimised, and you have more control over moisture management. The volume of the product is maximised and difficult products are easier to bake. Productivity can be

substantially increased (up to 50 percent or more). In addition, cooling time is reduced to almost zero, without the need for additional cooling energy. Vacuum cooling will therefore significantly reduce your energy consumption — and thus your ecological footprint.

In order to ensure that the integration of the vacuum cooler in your company goes smoothly, Weber Cooling's (baking) specialists offer support during the entire implementation process. Together, we will look at how you can use this new technology to optimise the quality and shelf life of your products. We will ensure the shorter baking times at the right oven temperatures. Where needed other adjustments will be advised, needed to arrive at first-class products.

We will also consider how you can exploit the benefits of the vacuum cooler to maximise your productivity. This can be done at your location and/or in our state-of-the-art Bakery Innovation Academy in Vlaardingen (NL), or in our research laboratory in Tokyo (Japan).



Vacuum cooling has **high added value** in terms of quality, savings and efficiency

This is what I want to tell as many bakeries as possible about, from small artisan bakeries to large bakeries (at industrial scale). Not everyone has heard of this technology, let alone works with it.

My name is Michel Schröder. I have been a baker for exactly half of my life; I started working in a bakery as a 19-year-old and learned the finer points of the trade there. Then I started working at a bakery wholesaler and before I started at Weber I worked at two suppliers in the bakery industry.

Unlike most people who start with a course and then put that knowledge into practice, my training as a baker was the exact opposite. I started out in the kitchen kneading the dough and only developed an interest in the theoretical aspects later on.

My passion for bread grew quickly. I am fortunate in that my work is also my hobby; I now have a small bakery at home and often spent my free time baking there. I came into contact with Weber Cooling through my network. We occasionally collaborated on an assignment and their vacuum cooling technology appealed to me immensely. There is so much potential for this technology in the bakery industry that I decided to join Weber full-time.



➤ Michel Schröder

- Professional baker since 2003
- Sales Manager Bakery
- Vacuum Cooling Specialist

I have been a member of the Dutch Boulangerie team since 2012.

In 2015, I won the European Bakery championship in France, and in Italy in 2020, I was awarded 1st prize in the “Bread in the City” category for the best Ciabatta, the best Pizza and the best “nutrition bread”.

I have worked at Weber Cooling as a Bread and Pastry Vacuum Cooling Specialist since 2021.





Together with the other Weber Cooling specialists, I can help you redesign your baking process to make the most of this new, energy-efficient, quality-enhancing and time-saving technology.

Customer Oriented Approach

I have worked as a baker for almost 20 years, so I know exactly what goes on in a bakery. Working with highly respected bakers around the world has helped me to deepen my knowledge. The most important thing they taught me is that the possibilities in baking extend beyond what I imagined.

This is the knowledge and experience that I bring to Weber Cooling. A great opportunity for you as a baker. “Why?” you may ask. Because you can get the most out of your products with Weber Cooling and my knowledge and experience. Weber Cooling provides a demo and I help you integrate the machine into the baking process in your own bakery, matched to the raw materials you use. And I obviously help you set things up after you purchase your own machine to familiarise you with the process. We also offer advice on recipes and I am always happy to help you with changes in production.

Savings in energy and time

The huge energy and time saving when you use Weber Coolers is a major advantage. Shortening the baking process lets you make your product in less time and reduces your energy costs.

A third benefit is that the baking process becomes more efficient without sacrificing product quality. On the contrary!



Seeing is believing

View our videos on Vimeo. We included around 25 videos. The most interesting are:

- **Interview - Bakery Gehr on results for various types of bread**
- **Customer Visit Scandinavian Bakery WeBake**
- Vacuum Cooling **Single Solution** Wiltink (NL)
- Vacuum Baking **Double Solution** Bakery Gehr (DE)
- Vacuum Baking **Triple Solution** Crelem Bakery (BE)
- Vacuum Cooling **Pound Cake**
- Vacuum Cooling **Toast**
- Vacuum Cooling **Biscuit for filled cake**
- Vacuum Cooling **Gluten Free Bread**
- Vacuum Cooling **Gluten Free Muffins**

[Watch our videos →](#)



Benefits of vacuum cooling



Croissants and danish pastries

Vacuum cooling allows you to bake the perfect croissant: maximum volume, beautiful airy layers, deliciously brittle on the outside, and soft on the inside. The structure is strong and retains its shape for a long time. Danish pastries are also baked to perfection. Baking time is reduced by an average of 30 percent, while cooling takes about 90 seconds.

French bread, baguettes and crusty rolls

Cooling is made easy and fast (within one to two minutes) with vacuum, while saving up to 40 percent on baking time. This bread gets a perfect, thin and crispy crust and a bouncy, resilient texture. Because it stays fresh throughout the day, there is less need for multiple baking rounds and deliveries.



Toast, casino and sandwich bread

Vacuum cooling also reduces baking and cooling times for these types of bread. For toast, form stability is key. High quality is more easy to achieve, both on crust & crumb. The product can be cut faster, which in turn reduces space utilisation and the number of carts required, optimising productivity.

Hamburger (buns)

Vacuum cooling gives buns perfect stability and volume. The baking time is also reduced, resulting in minimal baking loss. Packaging the bread when at a slightly higher temperature creates the perfect soft crust. There are benefits in terms of both freshness and shelf life.

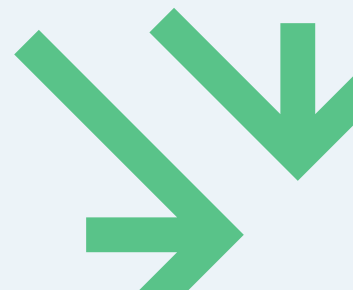

Benefits of vacuum cooling



Multigrain and artisan bread

The quality of the bread is optimised by properly aligning baking and vacuum cooling parameters. Thanks to an intense process of gelation with vacuum, the shelf life of bread is extended (delayed retrogradation). The perfect crust stays crispy longer, while baking times are reduced by up to 40 percent.

Gluten-free bread

Vacuum Cooling is a game changer for preparing gluten-free products and the process can offer a huge quality improvements. Thanks to the pulling effect during vacuum cooling, the bread structure is optimised and the volume maximised. Baking time is reduced by up to 40 percent and the bread can be sliced faster, better and at higher temperatures.



Cake, muffins and biscuits

By applying vacuum cooling, you can achieve perfect quality and maximum volume, while enjoying increased productivity and keeping cooling times to a minimum. In addition, biscuit get the same volume with decrease in ingredients used. Muffins come out with a big and bold top, a perfect flavour and a delicious bite.

Other breads and pastries

For almost all other bread and pastry products, applying vacuum cooling does not only lead to shorter baking and cooling times, but also advantages in terms of shape, volume, crumb and structure.



WeBake features

The affordable vacuum coolers for bakeries

Weber Cooling only builds vacuum coolers. So it is no surprise that we have become experts at it! All vacuum coolers are designed by our Dutch engineering team and are built with high-quality European components. Thanks to our economies of scale, our intelligent design and our strategically positioned and highly efficient production sites in Europe and Asia, we are able to offer excellent value for money.

Top Quality

At an affordable cost

Maintenance free

Most advanced Vacuum Technology

Energy Saving

Thanks to innovative

WeCool Software

Intuitive & easy to use

Optimum Process Control

Yet simple programming

Quality

- SU 316 stainless steel chambers with sight glass
- Anti-drip system on ceiling
- False floor with automatic water collection system and drainage
- Automatic stainless steel ramp and protective bumpers
- Dutch Design; produced in accordance with CE and/or UL regulations
- Vacuum technology by Burkert, Busch & Leybold - high performance and perfect control
- Cooling technology: Aermec chillers with minimal carbon footprint and lowest TCO
- Control and electronics: Siemens, Schneider, Klöckner Möller, for maximum reliability

Maintenance

Leybold's latest generation of oil-free NovaDry vacuum pumps are completely maintenance free and offer perfect process control. Virtually no maintenance is required, reducing your operational costs to the bare minimum.

Energy Consumption

Thanks to our intelligent alignment between vacuum and cooling technology, you only need about 1 kWh to cool down one standard rack (with 60 kg/130 lbs of bakery products). With the help of the Free Cooling Technology, this can be reduced to about 0.6 kWh! What's more, heat recovery allows you to use all the energy in the form of water heating.

Process control

The WeCool software is intuitive and enables fast process optimisation, for every product. The optimal cooling curve settings can be easily stored and managed. The complete step-by-step control of the cooling speed is achieved by using proportional valve technology.

Modular design

Our vacuum coolers can be easily adapted to your needs and come in various quality levels:

WeBake Base

Cost Optimised

WeBake Sense

Ideal price-quality ratio

WeBake Power

Top Quality



Vacuum cooler demo

Test it yourself in your own bakery!

Would you like to experience the possibilities that vacuum cooling can offer? Then Weber Cooling's research vacuum coolers are a perfect option: compact in size and affordably priced. Also available for rental. Our systems allow you to discover the full potential of this innovative technology and optimize your own product range.



Weber Cooling has two test vacuum coolers: for baking trays sizes 400×600 and 600×800. Both systems are equipped with full PCL control, allowing you to set the perfect cooling curve for your products.

WeBake 10 R

Small Research Vacuum Cooler
Designed for 400×600 mm baking trays, also suitable for 3/4 US trays (15"×21")
Designed for loads up to 10 kg/20 lbs. within 2- 8 minutes
500 × 700 × 800 mm 19.7" × 27.6" × 31.5" net interior space (w × d × h)
A cooler suitable for three (200 mm gap 7.9") or four (150 mm gap 5.9") baking trays
Fully proportional pressure control, with intuitive Siemens PLC control

WeBake 20 R

Small Research Vacuum Cooler
Designed for 600×800 mm baking trays, also suitable for US trays (18"×26")
Designed for loads up to 20 kg/45 lbs. within 2- 8 minutes
700 × 900 × 1000 mm 27.5" × 35.4" × 39.4" net interior space (w × d × h)
A cooler suitable for three (200 mm gap 7.9") or four (150 mm gap 5.9") baking trays
Fully proportional pressure control, with intuitive Siemens PLC control



The Standard WeBake Range

Our standard range includes three models, each designed for one or two medium or large carts.
The standard chamber dimensions are suitable for almost any size cart and relevant cooling capacity.

WeBake 40 Compact Rack Solution	WeBake 80 Single Rack Solution	WeBake 160 Double Rack Solution
<p>Available in two variants: SENSE and POWER CE/UL. One vacuum chamber can serve up to five ovens. If more ovens are used, multiple chambers can be combined with one central cooling system.</p>		
<p>The WeBake 40 is designed for small (American and Japanese) carts and can be built in a very compact size.</p>	<p>The WeBake 80 is designed for most European single carts and American double carts.</p>	<p>The WeBake 160 is designed for two carts. Most (European) cart models fit in a chamber.</p>
<p>The system is designed for cooling loads up to 40 kg/90 lbs, within 2-8 min.</p>	<p>The system is designed for cooling loads up to 80 kg/180 lbs, within 2-8 min.</p>	<p>The system is designed for cooling loads up to 160 kg/360 lbs, within 2-8 min.</p>
<p>750 × 900 × 1900 mm 29.5" × 35.4" × 74.8" net interior space (w × d × h)</p>	<p>900 × 1200 × 2100 mm 35.4" × 47.2" × 82.7" net interior space (w × d × h)</p>	<p>1200 × 1500 × 2100 mm 47.2" × 59.1" × 82.7" net interior space (w × d × h)</p>



Multi Chamber & Custom Systems

Our standard machines can be adapted to your specific wishes. Multiple chambers can be combined with one central cooling system, providing you with the lowest cost, highest productivity and greatest flexibility.

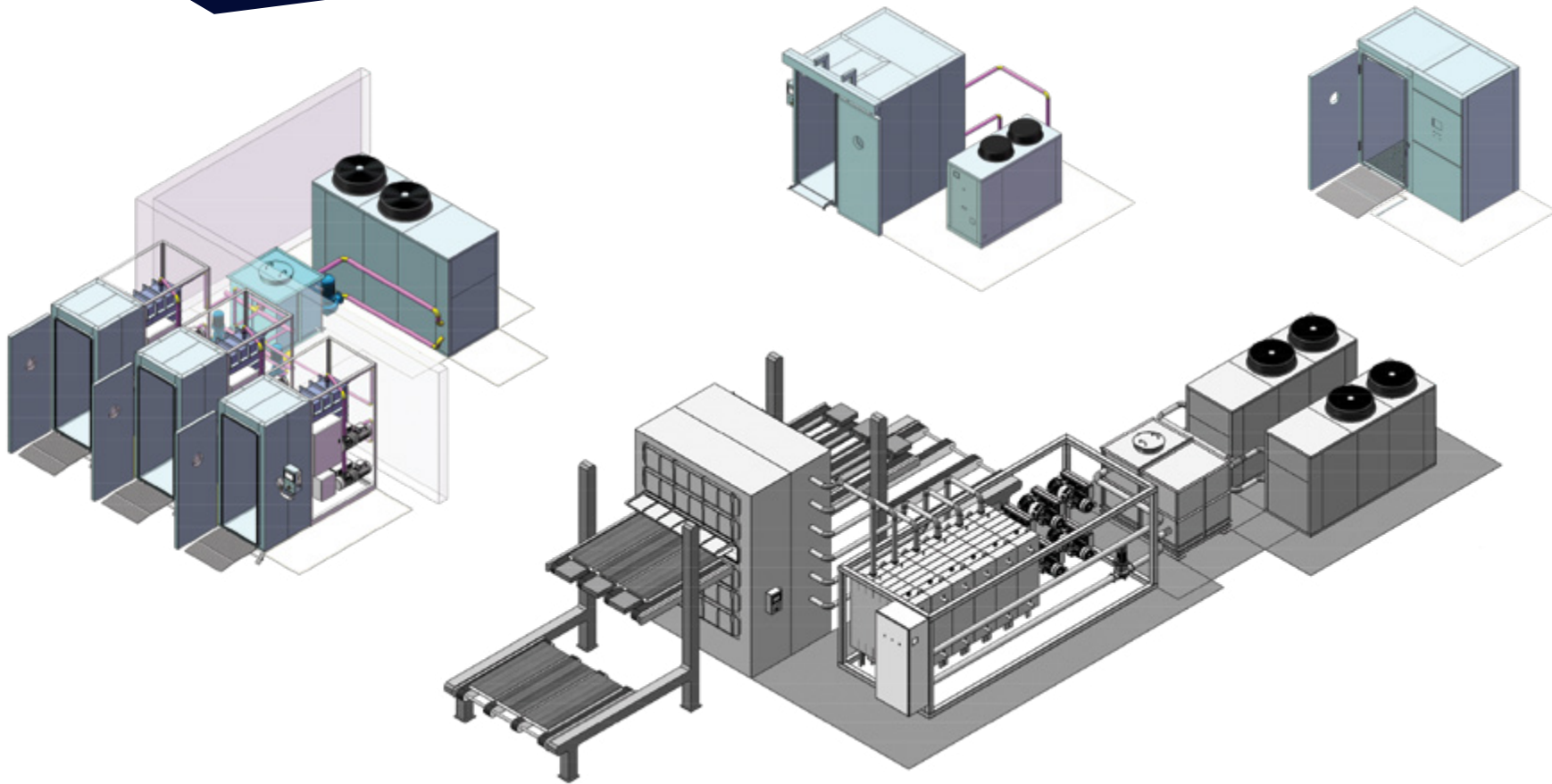

Support - We Care

With regional offices in Europe and Asia and a global network of more than 25 sales and service partners, we offer fast and reliable maintenance and support to all our customers.

Installation

To ensure the fastest installation process at the lowest possible cost, we work with local specialists. Our technical specialists prepare the installation and offer on-site support.

Implementation

To guarantee optimal results, Master Boulanger Peter Bienefeld and his team will provide support as long as necessary when integrating the vacuum cooler into your own baking process. Support is provided onsite or remotely depending on needs and circumstances.

Maintenance & support

We offer maintenance and support packages, compiled by us or by one of our partners. To unburden you is our goal. Now and in the future.

Contact

Weber Cooling B.V.

General Export

The Netherlands
+31 884 256 250

info@webervacuum.group

Weber Cooling Europe Kft.

Eastern Europe

Hungary
+36 309 926 048

info@webervacuum.group

Weber Cooling Asia Ltd.

Asia-Pacific

Hong Kong
+85 258 030 317

info@webervacuum.group

Weber Cooling China Ltd.

China

+86 2150 689 019

info@webervacuum.group

What our clients say about us?



Gluten Free Power 120 Bakkerij Wiltink (NL)

We were one of the first bakeries in the Netherlands to opt for Weber Cooling.

The low cost was certainly a consideration. Our WeBake Power has been running for more than five years now, without any problems or difficulties!

Artisan x2 Power 120 Bäckerei Gehr (DE)

We have replaced our old, German vacuum coolers with two new WeBake Power systems, for half of the cost. This high-quality model is perfect for cooling all our bakery products.

Viennois x3 Sense 60 Crelem Bakeries (BE)

We installed three WeBake Sense chambers at one of our bakeries. A modest investment with two major benefits: quality optimisation and a 50 percent increase in productivity.



webervacuum.group